

Submersible sump pump made of stainless steel AISI 304, double mechanical seals ensure long life and reliability. Suitable for draining wells, plant room sump, lift shaft emptying, pools, sumps, irrigation, and water displays. Options include with or without float switch. Solids handling up to 10 mm



SPECIFICATIONS

- Maximum liquid temperature: 35°C
- Maximum immersion: 10 m
- Maximum passage of solids: 10 mm

MATERIALS

- Pump casing, impeller, strainer, cover, casing cover and motor casing in AISI 304
- Shaft in AISI 303
- Double mechanical seal with interposed oil chamber upper in carbon-ceramic/NBR - lower in SiC/SiC/NBR

TECHNICAL DATA

- Asynchronous 2 poles motor
- Insulation class F
- Protection degree IP68
- 1~230V ± 10%, 50Hz - 3~400V ± 10%, 50Hz
- Permanent split capacitor and automatic thermal overload protection for single-phase version
- Thermal protection to be provided by the user for three-phase version
- Discharge 1 1/2"

DIMENSIONAL TABLE

Pump type	(mm)		Weight kg
	H	H1	
BEST 2	352	315	12
BEST 3	352	315	12.7
BEST 4	377	340	13.8
BEST 5	377	340	13.5

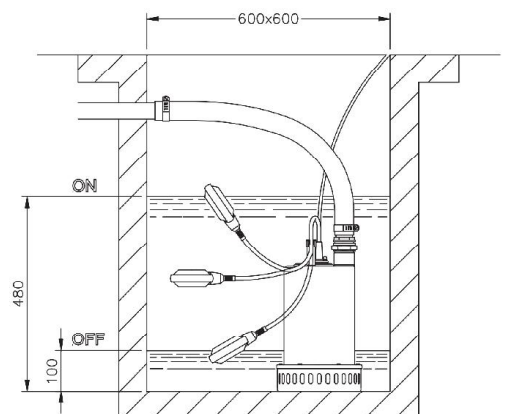
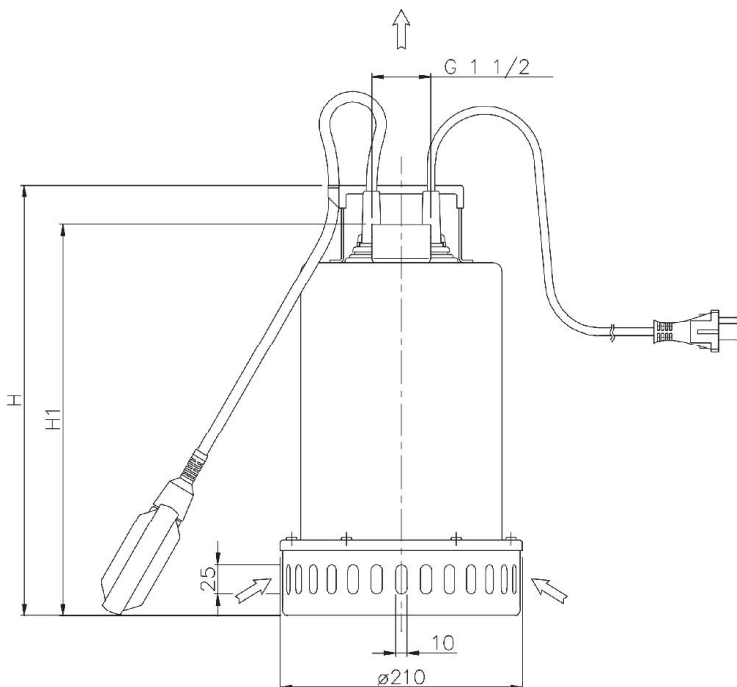

PERFORMANCE CURVES (according to ISO 9906 Annex A)

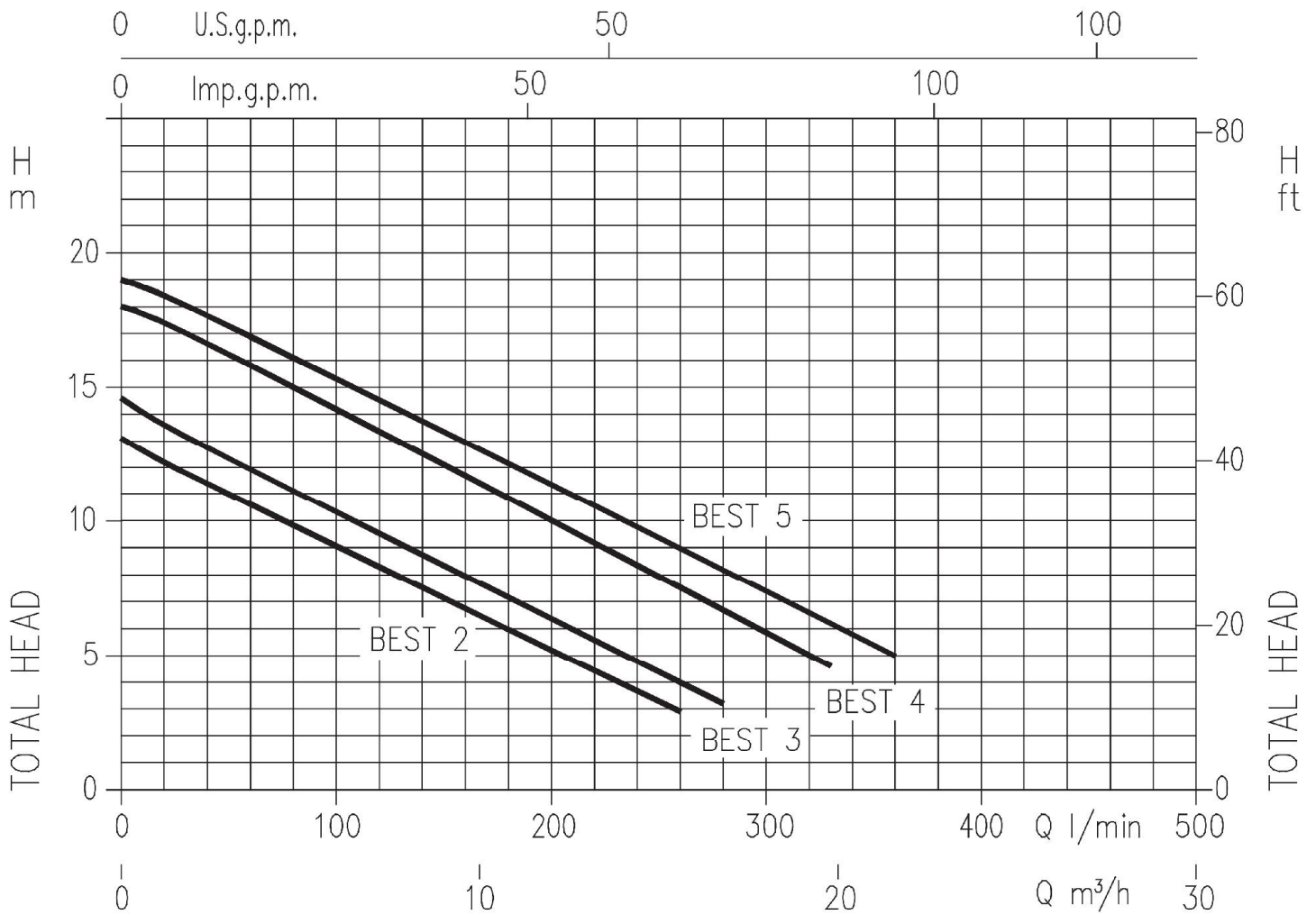

PERFORMANCE TABLE

Pump type		kW	Capacitor		Absorbed Current (A)		Q=Capacity														
Single-phase	Three-phase		μF	V _c	1~	3~	l/min	20	40	80	120	160	170	200	260	280	300	330	360		
								m³/h	1,2	2,4	4,8	7,2	9,6	10,2	12	15,6	16,8	18	19,8	21,6	
								H=Total head													
BEST 2 M	BEST 2	0,55	16	450	4,4	2,0	12,2	11,4	9,8	8,3	6,7	6,3	5	2,9	-	-	-	-	-	-	-
BEST 3 M	BEST 3	0,74	20	450	5,6	2,4	13,6	12,7	11,1	9,5	7,9	7,6	6,4	4	3,2	-	-	-	-	-	-
BEST 4 M	BEST 4	1,1	30	450	7,3	3,0	17,4	16,6	15	13,4	11,7	11,3	10	7,5	6,7	5,9	4,6	-	-	-	-
-	BEST 5	1,5	-	-	-	3,3	18,4	17,7	16,1	14,5	12,8	12,5	11,4	9	8	7,4	6	5	-	-	-