

# TAS-250/400/750

## Sump Pumps

# TAS-250/400/750

## Sump Pumps

FOR: VIETNAM , TAIWAN

### Đường cong / Curve

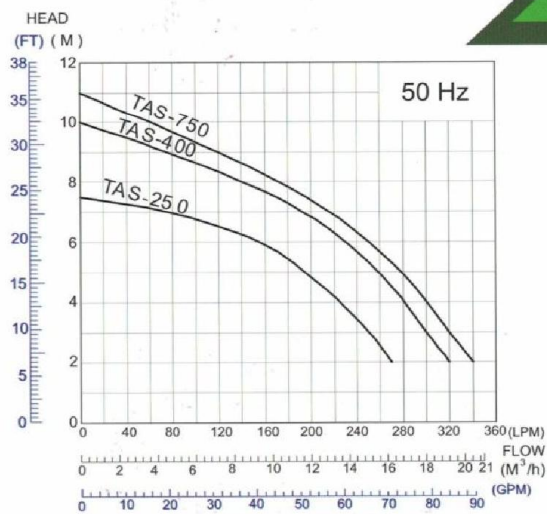

- Liquid temperature: 0~40°C / 32~104°F
- HP range: 1/3~1 HP / 250~750W
- PH value: 6~8
- Rated speed: 2900 / 3450rpm
- IP class: IP68
- Max. depth: 8M

### Tính năng / Features

Full cast iron Motors barrels  
Fast heat dissipation, not easily deformed  
Cast iron Middle  
Match split mechanical seal  
Cooling fast, excellent waterproof

### Ứng dụng / Applications

- 1, sewage and waste water discharge
- 2, environmental protection, system integration

### Đặc điểm kỹ thuật / Specification

Model No.	Output		Outlet		Pass Solid (mm)	Max Flow (LPM)	LPM Flow @ Head					Max Head (M)	Weight (Kg)
	HP	W	mm	inch			3M	4.5M	6M	7.5M	9M		
TAS-250	1/3	250	40	1.5"	14	270	250	210	155	-	-	7.5	8
TAS-400	1/2	400	50	2"	14	320	300	270	230	170	75	10	9
TAS-750	1	750	50	2"	14	340	320	290	250	195	120	11	10

# 24

TAS-250/400/750

**Cắt View / Sectional View**

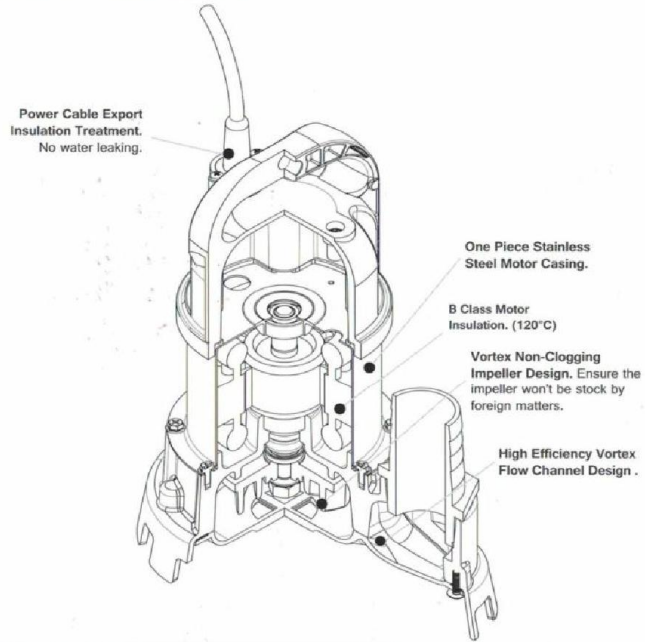

**Kích thước / Dimension**

Model	L	W	H	H1	H2	H3	G
	mm	mm	mm	mm	mm	mm	inch
TAS-150	225	163	282	164	85	83	1 ½
TAS-250	225	163	282	164	85	83	1 ½
TAS-400	250	178	323	168	84	84	2
TAS-750	250	178	353	186	78	84	2

**Các phụ kiện tiêu chuẩn / Standard Accessories**

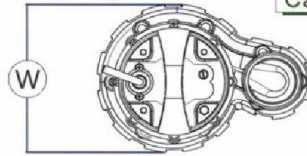

Model No.	Accessories
TAS-250	Hose connection
TAS-400	Hose connection
TAS-750	Hose connection

**Sơ đồ chức năng / Schematic Function**

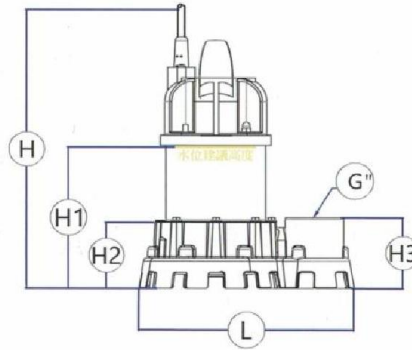
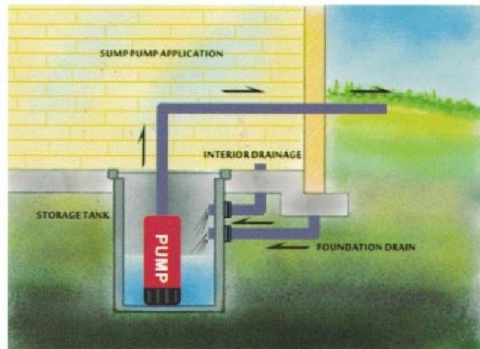

**xác nhận / Certification**

